

MODEL 301-10 (10 ft. arm)
MODEL 301-12 (12 ft. arm)
MODEL 301-14 (14 ft. arm w/ counterbalance)
MODEL 301-16 (16 ft. arm w/ counterbalance)

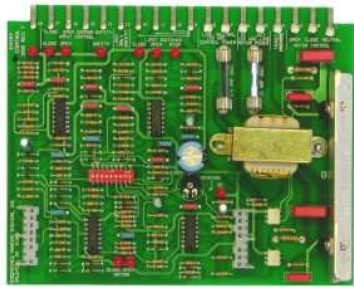

Barrier Gate

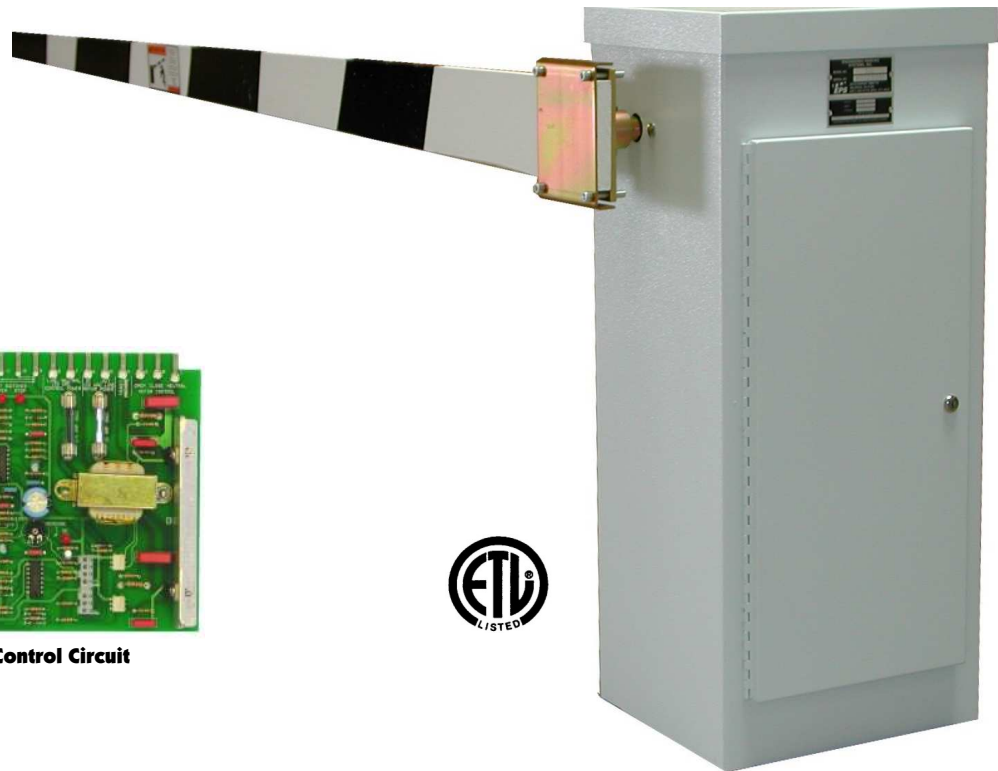

Plug-in Control Circuit



FEATURES:

- 100% Solid State plug-in control circuit
- Rugged weather resistant, 10 gage steel housing
- Theft and tamper resistant, no exterior mounting bolts
- Easy access to drive mechanism through hinged, locked weatherproof cover
- Access to controls through all-weather, locked side door
- Gate arm rebound feature

OPTIONAL EQUIPMENT:

- Folding gate arm where ceiling height limitations are encountered
- Card readers
- Push button controls
- Radio controls
- Revenue control equipment
- Open on power failure (battery back-up)



ENGINEERED PARKING SYSTEMS

25010 AVENUE TIBBITTS, VALENCIA, CA 91355
PHONE (661) 294-0778 (800) EPSINFO (377-4636) FAX (661) 294-0674
www.epsinfo.com

EQUIPMENT SPECIFICATIONS

PARKING GATE: MODEL 301

A. HOUSING:

The housing shall be weatherproof and constructed of ten (10)

Gauge cold rolled steel. All seams, joints, and supports shall be electric bead welded. (Spot welds are not acceptable for the housing construction).

Access to the motor compartment shall be provided by a top lid, secured by a latch located within the housing. Access to the interior of the housing shall be provided by a key locked door. The door and the top lid shall be designed to retard against unauthorized entry, tampering and vandalism. An opening of 7" x 9" for conduit stub-ups shall be provided at the base of the unit.

The cabinet shall be finished with primer and either White or Cardtex Beige powder coat to insure lasting beauty and protections.

B: CONTROL CIRCUITRY:

All control circuitry, logic, motor starting circuitry, etc. shall be contained in one (1) easily removable, semi-sealed, housing (hereafter referred to as the control logic assembly). All connections to the control circuitry compartment shall be made by Jones plugs.

One (1) standard control logic assembly shall be capable of providing all system logic as well as manual functions and shall be of solid state design. No relays or contactors shall be accepted in this unit.

Operational mode changes shall be accomplished by dip switches located on the control board. No circuitry modification, addition, or deletion shall be required to accomplish standard mode variations.

C: ELECTRICAL CHARACTERISTICS:

Phase input shall be fed through a series trip magnetic circuit breaker of U.L. listed type. This circuit breaker shall disconnect all cabinet power as well as offering electrical overload protection in the gear motor circuit and primary cabinet power circuits.

D. MECHANICAL:

The gate arm shall be driven by ½ horsepower, 115 VAC single phase instant reversing motor. The motor shall be connected by a V-belt to a heavy duty, 60:1 ratio, single reduction speed reducer.

E. GATE ARM REBOUND:

The reverse sensing circuit shall be a standard feature and shall be controlled by motor current. If the gate arm comes in contact with an object during the closing cycle, sufficient non-destructable pressure shall cause the gate motor driver to instantly reverse and return the gate arm to the full open-position.

Pressure applied to the gate arm once it is in the full close position shall not activate the gate motor to re-open. The reverse sensing shall be a part of the control logic assembly in the locked gate housing.

External or mechanical switching to accomplish gate arm rebound shall not be acceptable.

F. OPTION:

One option to be included for installation with limited overhead clearance is the folding gate arm.

The gate arm shall be comprised of two (2) wooden pieces firmly supported by metal brackets and a single adjustable steel rod. Wooden brackets and cables shall not be acceptable.

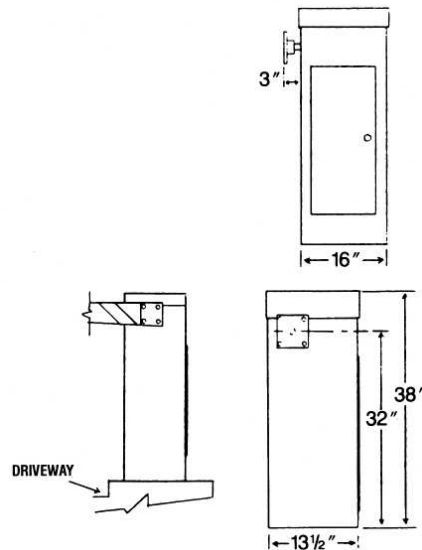
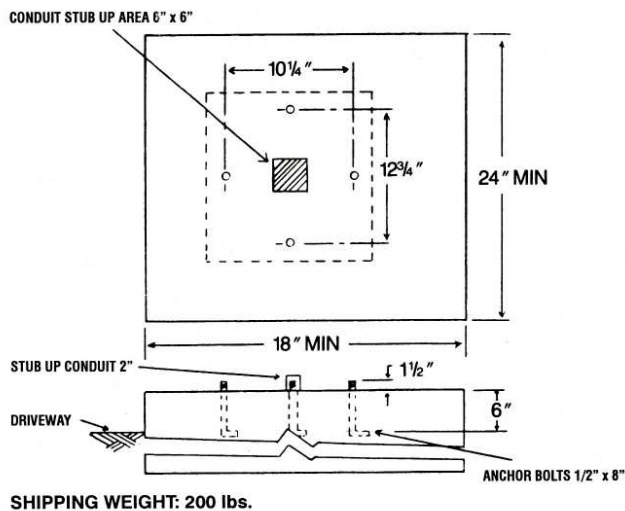

ENGINEERED PARKING SYSTEMS

25010 AVENUE TIBBITTS, VALENCIA, CA 91355

PHONE (661) 294-0778 (800) EPSINFO (377-4636) FAX (661) 294-0674

www.epsinfo.com